

External Venetian Blinds



Cedar Slats: C

Slat Widths:

Available Colours: Natural oiled finish

Contents:

1. Cedar Slat
2. Cable guidance
3. Rail guidance
4. Motor Drive
5. Crank drive
6. Dimension table
7. Stack height table
8. Weather cover/ Pelmet

Our cedar slat version offers the significant benefits of external sun shading combined with a warm natural appearance. Premium Western Red Cedar is coated with SIKKENS clear finish to enhance the natural colors and provide long lasting protection. Over time the color will soften to grey, harmonizing with other timber elements of the design.

Features:

- 6mm slat thickness provides excellent resistance to deflection.
- Unique rigid base rail maintains a neat and level stack appearance when retracted.
- A range of Sikkens “Cetol” & “Supernatural” stain colors can be selected.
- Clear lacquer finish available for internal applications.
- Daylight guidance feature available
- Tilts through 160 degrees
- Special coated stainless steel guide cables.
- Other suitable timber species are possible.

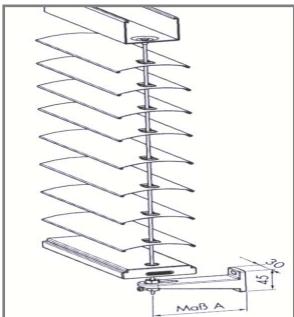

Cable Guidance: A2

Available thickness: 3.3mm

Available colours: Black/ Transparent

Polyamide coated stainless steel guiding cables with an $\varnothing 3.3\text{mm}$ are fixed in to the top rail of the external venetian blind and run through perforations of all slats to the end rail and are fixed to the window or wall by means of a suitable aluminium tension angle.

Features:

- Cable guides allow lateral guidance control for external venetian blinds with minimal visual impact.

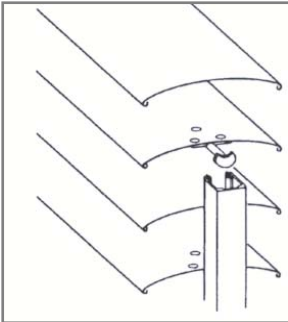

Rail Guidance: A6

Available Types: Various

Available colours: Natural anodized/ RAL powder coat range

A range of extruded aluminium rail guides are available in various profiles to virtually suit any application.

Features:

- A black plastic sealing strip is inserted for sound absorption.
- Every third slat on a venetian blind is fixed with guiding nipples on both ends made of reinforced polyamide.
- Guide rails are the most stable form of guidance.



Crank Drive: C

Maintenance free bevel gears drive with an integrated brake.

Crank operation: Lifting and tilting of blinds is done via an articulated crank and crank rod made of an aluminium tube.



Motor Drive: E

Maintenance-free 230V covered electric motor with integrated limit switches and thermal protection switch

Motor operation: Lifting and tilting of the blinds is done via a wall switch/ remote control or Warema Control System (with connection into BUS systems if required)

Cable guidance



Tension cable bracket

■ Type S 01



Tension cable bracket

■ Type SH 02 with cross plate



Tension cable bracket for mullion-transom (MT) facades

■ Type SF 21



Tension cable bracket for mullion-transom (MT) facades

■ Type SF 22



Tension cable bracket for mullion-transom (MT) facades

■ Type SG 21



Tension cable bracket for mullion-transom (MT) facades

■ Type SG 22



Tension cable bracket for floors and window sills

■ Type S 04



Tension cable bracket for corner installations

■ Version 1



Tension cable bracket for corner installations

■ Version 2



Spring tension device

To compensate for lengthwise extension of the tension cable, integrated "unobtrusively" into the top rail of the external venetian blind



Tension bracket, large

Guide rails



Type 1, angled

- 25 x 18 mm
- Wall-mounted



Type 2, angled

- 25 x 18 mm
- Fits on guide rail brackets



Type 3, angled

- 50 x 18 mm
- Central guide rail to guide two blinds
- Fits on guide rail brackets



Type 4, round

- Ø 32 mm
- Fits on guide rail brackets



Type 7, round

- Ø 52 mm
- For use with self-supporting external venetian blinds



Type 8, round

- Ø 52 mm
- Central guide rail to guide two blinds
- For use with self-supporting external venetian blinds



Type 9, angled

- 25 x 50 mm
- For use with self-supporting external venetian blinds



Type 10, angled

- 50 x 50 mm
- Central guide rail to guide two blinds
- For use with self-supporting external venetian blinds



Fascia panel

- To reduce lateral incidence of light

Guide rail brackets



H 1

- Bracket for guide rail type 1, 2, 3, 4



H 101

- Bracket for guide rail type 7, 8, 9, 10

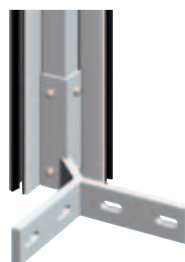

Corner bracket version 1

- Bracket for 90° external corner with 40 x 40 mm square tube and guide rail type 1

Cover panels

(Pelmet Types)



Cover panel ABL 01

- Angular cover panel, folded



Cover panel ABL 02

- Angular cover panel, with upturn beam



Cover panel ABL 03

- Angular cover panel, folded with upturn beam



Cover panel BL 04

- Angular cover panel, folded, sloped



Cover panel ABL 05

- Gallery cover panel



Cover panel ABL 06

- U-shaped cover panel, folded



Cover panel BL 07

- U-shaped cover panel, sloped on one side



Cover panel BL 08

- U-shaped cover panel, folded, angled on both sides



Cover panel BL 09

- Round-shaped cover panel, folded



Cover panel BL 31

- U-shaped cover panel, folded, to accommodate baseboards
- Optional 8 mm polystyrene baseboard available



Cover panel, special version, with perforations, grooves or special folds

- Available on request

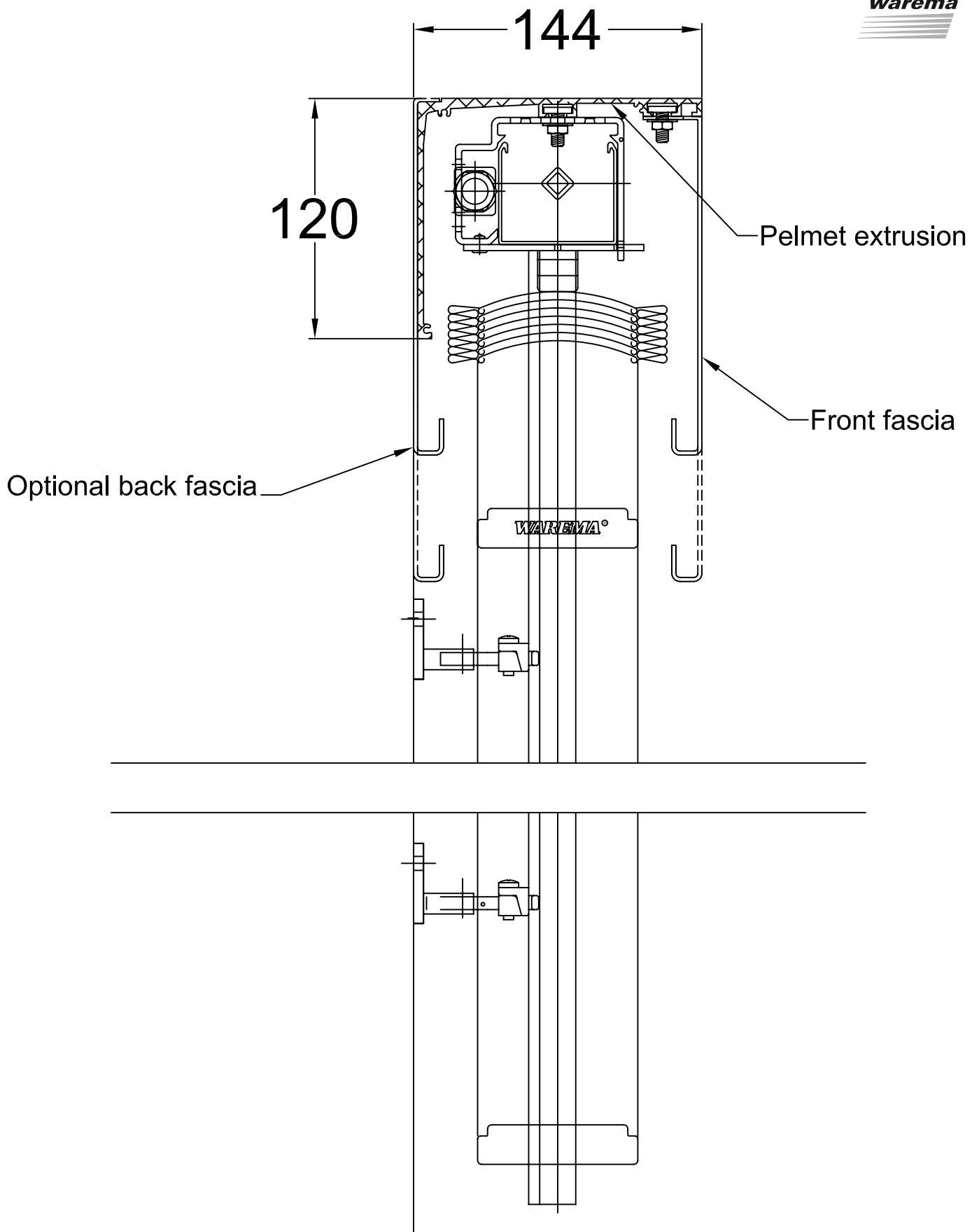

Detail Type ABL Pelnets